

EHS

Horizontal, Single Stage, Volute Casing Self-priming Centrifugal Pumps.

자흡식, 횡축, 단단, 볼류트 케이싱 원심 펌프

5Bar / PN 5Bar

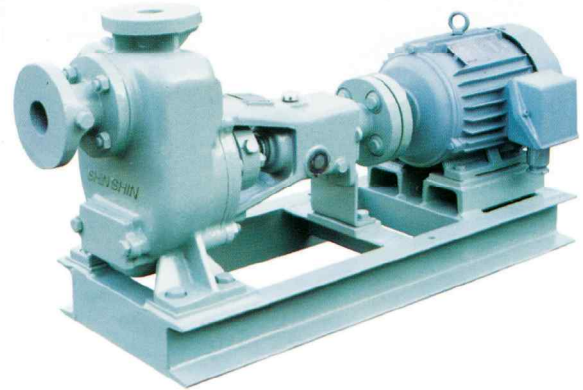

용도 및 적용분야 / Usages and applications

맑은 액체용 자흡식 펌프임.

광범위한 사용영역의 일반용도 펌핑에 사용된다. : 일반 산업용, 화학공업용, 선박용, 가정용 또는 도시 용수공급용, 농업용, 건축용수 학교용, 병원용, 소방용 등.

Self priming pump for clean fluids. For general purpose pumping in a wide range of application : general industries, chemical industries, marine use, domestic or town water supply, agricultural use, house builder's utility, hospitals, fire fighting use etc.

설계 및 구조적 특징 / Design and operation features

01. 플랜지는 흡토출 공히 KS 또는 JIS 5kg/cm²급, FF.
 02. 넓은 사용영역에 걸쳐 효율이 높고, 운전이 정숙하며, 고장이 적다.
 03. 펌프부품의 최대의 호환성.
 04. 라디알 방향 케이싱 분할.
 05. 임펠러 후방 취출 구조.
 06. 동평형된 임펠러
 07. 볼베어링 5300, 6300, 7300계열 등을 사용. 윤활방식은 그리스 또는 오일배쓰식임.
 08. 무냉각 스테핑 박스. 팩킹링 또는 메카니칼 씬 사용.
 09. 구동축에서 보아 우회전.
 10. 상하면을 기계가공한 용접 구조의 강재 베이스 플레이트.
 11. 수력 특성 및 구조 개선을 위한 정밀 셸모우드 구조.
 12. 부품의 정밀 가공.
 13. 특수액 펌핑용으로 별도의 재질 또는 주조 부품 사용가능.
- ※ 상기 사양범위를 초과하는 대형 펌프도 제작합니다.

01. Flanges are KS or JIS 5kg/cm² rating, FF.
 02. Good efficiency, smooth operation, and trouble free operation throughout a wide range of hydraulic coverage.
 03. Maximum interchange abilities of pump parts.
 04. Radially split volute casing.
 05. Impeller back pull-out arrangement.
 06. Dynamically balanced impeller.
 07. Ball bearings series 5300, 6300, and/or 7300 etc. Grease contained type or oil bath type lubrication.
 08. Uncooled stuffing box. Packing rings or mechanical seal.
 09. Colck-wise(CW) rotation when viewed form the drive end.
 10. Welded steel base plate, machined both up side and bottom side.
 11. Precision shell-moulded casings for better hydraulics and consistent casting integrity.
 12. Precision machining of parts.
 13. Special materials or casings for special liquid pumping.
- * The out of the above range can be supplied according to customer's order placement.

형식 표시 방법 / Type nomenclature

- ▶ 씨리즈(Series) _____
- ▶ 사이즈/흡입 구경(Size/Nominal dia. of suction nozzle) _____
- ▶ 양정 등급(Head ratings) : A,B,C..... _____

EHS-50B

선정표(60HZ에서) / Performance selection chart(60Hz)

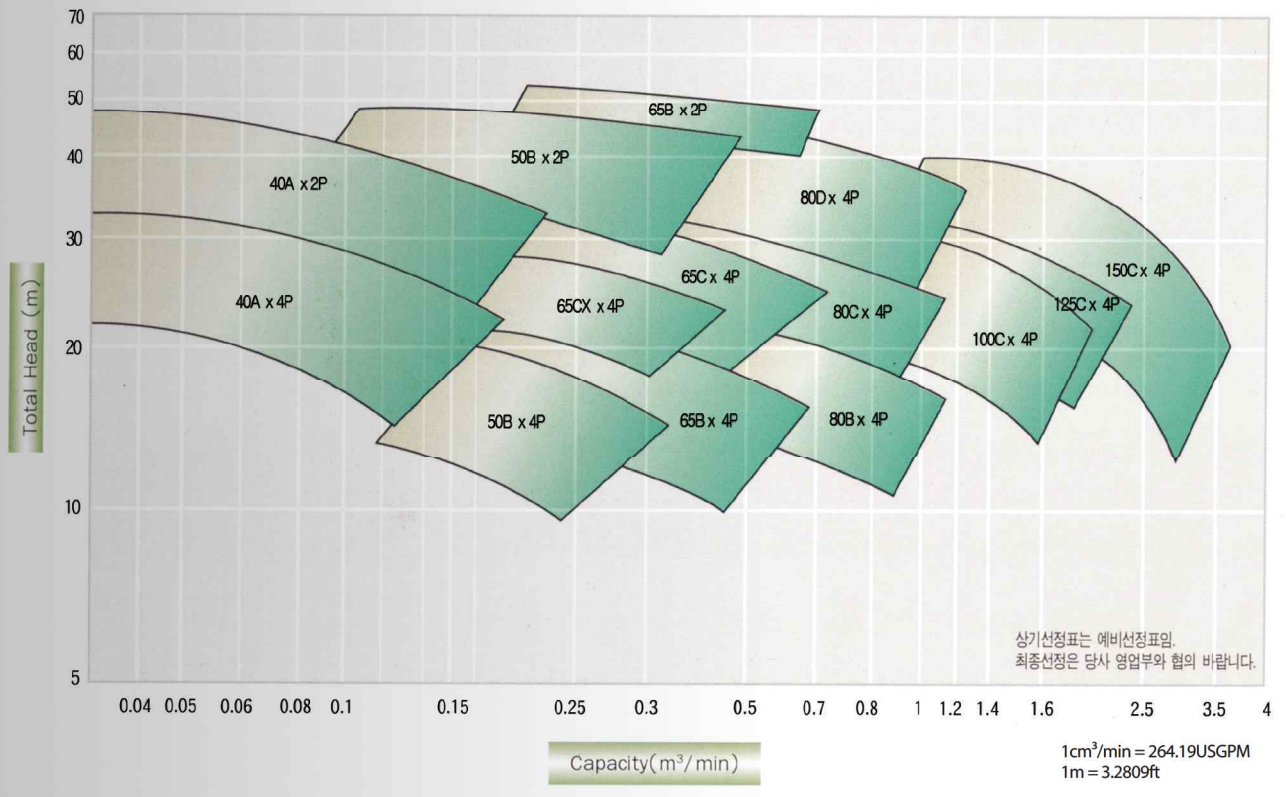

* The out of the above range can be supplied according to customer's order placement.

선정표(50HZ에서) / Performance selection chart(50Hz)

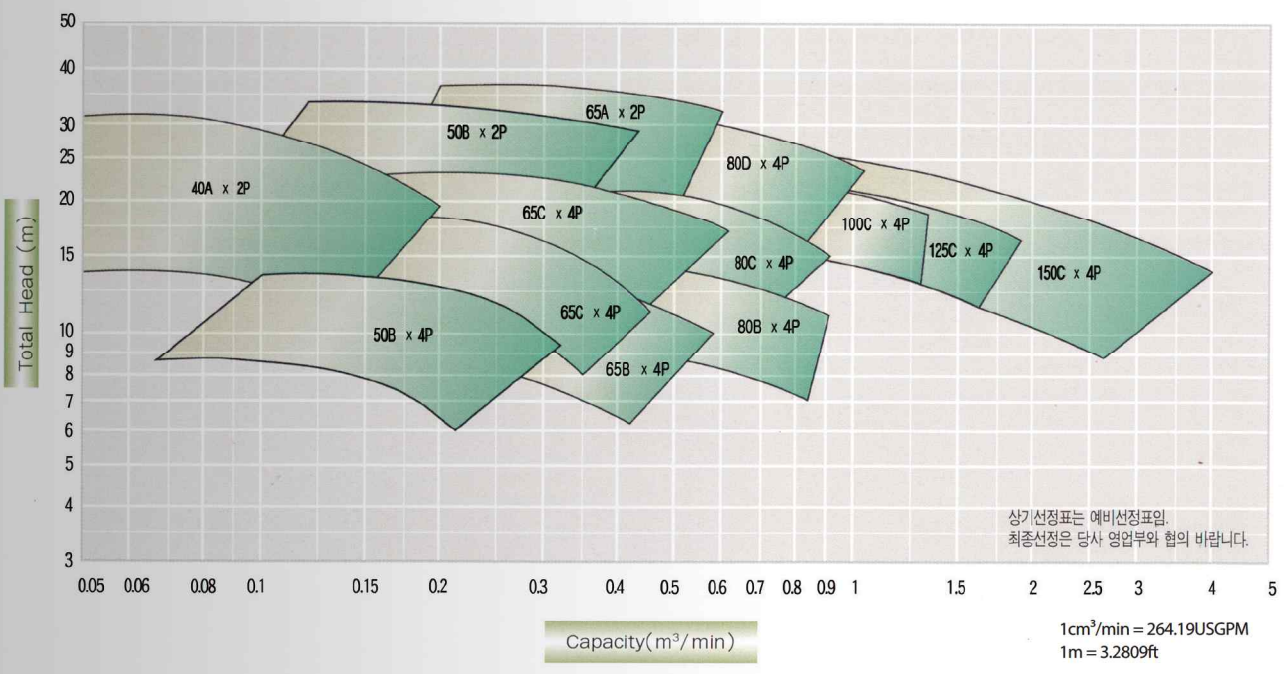

* The out of the above range can be supplied according to customer's order placement.

조립 단면도 / Sectional drawing

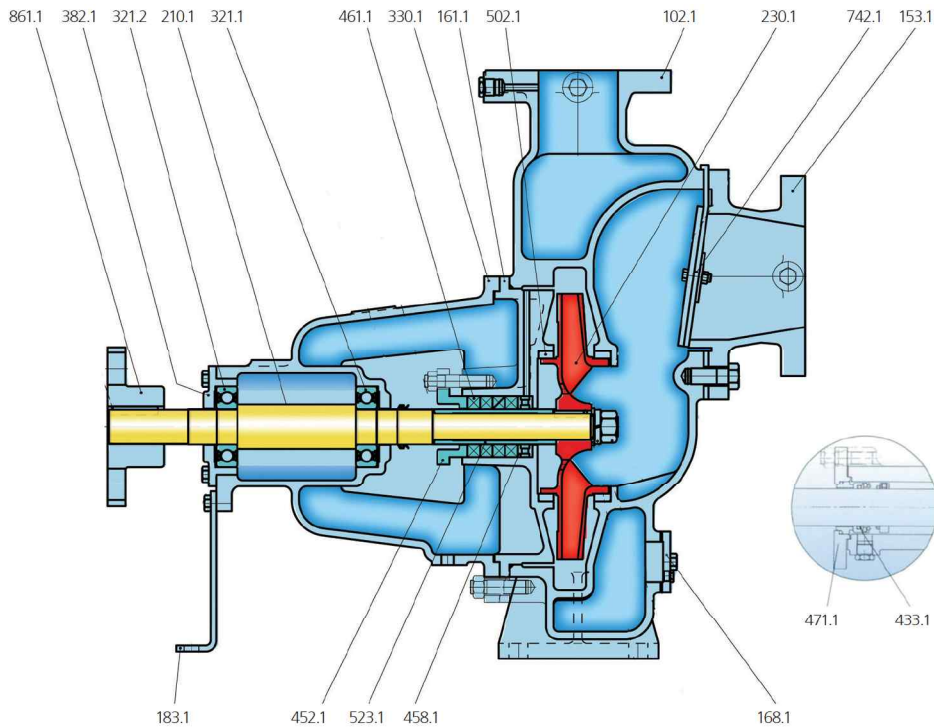

NO.	PART NAME	MATERIAL								Q'ty
		CLASS 1	CLASS 2	CLASS 3	CLASS 4	CLASS 5	CLASS 6	CLASS 7	CLASS 8	
102.1	VOLUTE CASING	GC 200	GC 250	CAC 406	SSC 13	SSC 14	SSC 16	GCD 450	SC 450	1
153.1	SUCTION BRANCH	GC 200	GC 250	CAC 406	SSC 13	SSC 14	SSC 16	GCD 450	SC 450	1
161.1	CASING COVER	GC 200	GC 250	CAC 406	SSC 13	SSC 14	SSC 16	GCD 450	SC 450	1
168.1	DRAIN COVER	GC 200	GC 250	CAC 406	SSC 13	SSC 14	SSC 16	GCD 450	SC 450	1
183.1	SUPPORT	SS 400								1
210.1	SHAFT	SM 45C / STS 304		STS 304		STS 316	STS 316L	STS 304		1
230.1	IMPELLER	GC 200 / CAC 406 / SSC 13		CAC 502 A / CAC 703		SSC 13	SSC 14	SSC 16	SSC 13	1
321.1	BALL BEARING	STB 2								1
321.2	BALL BEARING	STB 2								1
330.1	BEARING HOUSING	GC 200								1
382.1	BEARING CASE	GC 200								1
*433.1	MECHANICAL SEAL	-								1
452.1	PACKING GLAND	GC 200		CAC 406	SSC 13	SSC 14	SSC 16	GC 200		1
458.1	LATERN RING	CAC 406			SSC 13	SSC 14	SSC 16	CAC 406	SSC 13	1
461.1	PACKING	NON METALIC								1SET
*471.1	SEAL COVER	STS 304				STS 316	STS 316L	STS 304		1
502.1	CASING WEAR IRING	CAC 406 / SSC 13		CAC 502 A / CAC 703		SSC 13	SSC 14	SSC 16	SSC 13	2
523.1	SHAFT SLEEVE	STS 304				STS 316	STS 316L	STS 304		1
742.1	NON RETURN VALVE	STS 304 + C1220P + EPDM			STS304 + VITON	STS316 + VITON	STS316 + VITON	STS304 + C1220P + EPDM	STS304 + VITON	1
861.1	COUPLING	GC 200								1

* OPTION

외형치수도 / Outline dimensions

Fig "A"

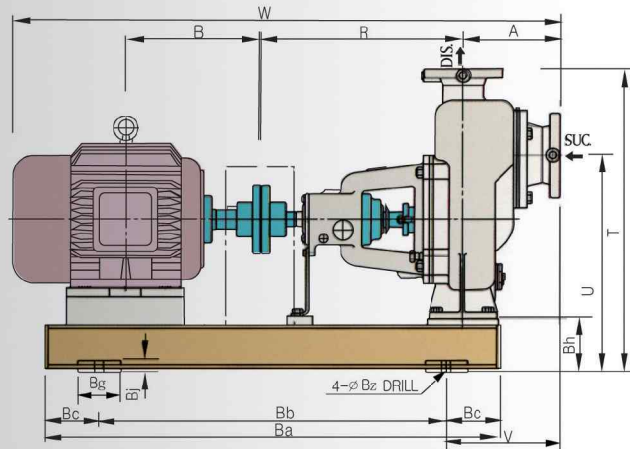

Fig "B"

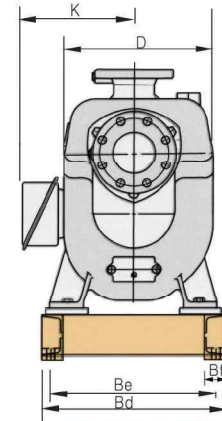
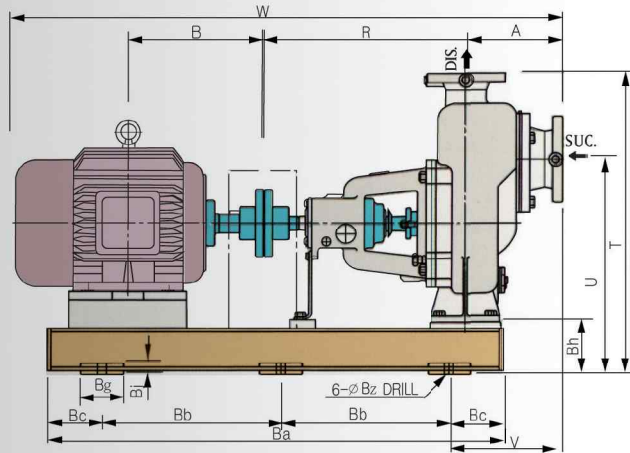

Fig "A" & "B"

• Dimensions for the standard unit driven by ICE standard motor.

TYPE	FIG	MOTOR FRAME NO.	BORE		PUMP & MOTOR DIMENSIONS(MM)										BASE PLATE DIMENSIONS(MM)						WEIGHT(KG)						
			SUC.	DIS.	A	B	D	K	R	T	U	V	W	Ba	Bb	Bc	Bd	Be	Bf	Bg	Bh	Bj	Bz	PUMP	MOTOR	BASE	TOTAL
EHS40A	A	80M	Ø 40	Ø 32	150	207	140	159	355	427	327	215	781	700	450	125	290	255	40	80	95	25	15	29	15	24	68
		168.5					174	215				843	700	450	125	24									28	84	
		193					196	215				880	700	450	125	30									28	87	
		200.5					206	215				885	700	450	125	315	280	39							28	96	
		239					229	240				947	800	500	150			56							32	117	
		258					229	240				985	800	500	150	70	32	131									
EHS50B	A	80M	Ø 50	Ø 40	178	265	140	159	355	523	365	248	809	650	450	100	315	280	40	80	95	25	15	47	15	28	90
		168.5					174	248				871	700	450	125	24									28	99	
		193					196	248				908	700	450	125	30									28	105	
		200.5					206	248				913	700	450	125	39									28	114	
		239					229	268				975	800	500	150	335	290	56							35	138	
		258					229	268				1013	800	500	150			70							35	152	
		323					294	293				1119	950	500	175	335	290	109							41	197	
		345					294	293				1163	950	600	175			50							100	120	28
351	317	293	1191	950	600	175	370	325	161	42	250																
EHS65B	A	90L	Ø 65	Ø 50	188	262	168.5	174	355	523	365	258	881	700	450	125	315	280	40	80	95	25	15	48	24	28	100
		193					196	258				918	700	450	125	30									28	106	
		200.5					206	258				923	700	450	125	39									28	115	
		239					229	283				985	800	500	150	56									35	139	

• 치수는 참고용임



EHS

• Dimensions for the standard unit driven by ICE standard motor.

TYPE	FIG	MOTOR FRAME NO.	BORE		PUMP & MOTOR DIMENSIONS(MM)									BASE PLATE DIMENSIONS(MM)									WEIGHT(KG)										
			SUC.	DIS.	A	B	D	K	R	T	U	V	W	Ba	Bb	Bc	Bd	Be	Bf	Bg	Bh	Bj	Bz	PUMP	MOTOR	BASE	TOTAL						
EHS 65B	A	132M	ø65	ø50	188	258	262	229	355	523	365	283	1023	800	500	150	315	280	40	80	95	25	15	48	70	35	153						
		323				294		308				1129	950	600	175	335	290	50	100	120	28	19	109		41	198							
		345				294		308				1173	950	600	175								136		41	225							
		351				317		308				1201	950	600	175	395	350	50	100	120	28	19	161		41	250							
		370				312		333				1261	1000	600	200								182		45	275							
EHS 65C EHS 65CX	A	90L	ø65	ø50	188	168.5	313	174	355	570	415	243	881	700	450	125	350	315	40	80	95	25	15	63	24	28	115						
		193				196		243				918	750	500	125	30									32	125							
		200.5				206		243				923	750	500	125	39									32	134							
		239				229		268				985	800	500	150	56									35	154							
		258				229		268				1023	800	500	150	70									35	168							
		323				294		293				1129	950	600	175	370									325	50	100	120	28	19	109	41	213
		345				294		293				1173	950	600	175																136	41	240
		351				317		318				1201	1000	600	200	395									350	50	100	120	28	19	161	45	269
		370				312		318				1261	1000	600	200																182	45	290
EHS 80B	A	100L	ø80	ø65	230	193	276	196	365	570	385	285	970	750	500	125	350	315	40	80	95	25	15	63	30	32	125						
		200.5				206		285				975	750	500	125	39									32	134							
EHS 80C	A	112M	ø80	ø65	205	200.5	337	206	470	670	470	295	1055	900	550	175	410	365	50	100	120	28	19	93	39	38	170						
		239				229		295				1117	950	600	175	56									41	190							
		258				229		295				1155	950	600	175	70									41	204							
	323	294				240		1261				1050	400	125	109	53									255								
EHS 80D	B	160M	ø80	ø65	215	323	384	294	470	670	470	255	1271	1050	400	125	440	395	50	100	120	28	19	103	109	48	260						
		345				294		255				1315	1050	400	125	136									48	287							
		351				317		280				1343	1100	400	150	161									51	315							
		370				312		280				1403	1100	400	150	182									51	336							
		425.5				364		255				1498	1150	450	125	295									53	451							
EHS 100C	A	132S	ø100	ø80	225	239	358	229	470	700	495	310	1137	950	600	175	440	395	50	100	120	28	19	96	56	42	194						
		258				229		310				1175	950	600	175	70									40	206							
		323				294		265				1281	1050	400	125	109									48	253							
	345	294				265		1325				1050	400	125	136	48									280								
	351	317				290		1353				1100	400	150	161	51									308								
	370	312				290		1413				1100	400	150	182	51									329								
	425.5	364				265		1508				1150	450	125	295	53									444								
EHS 125C	B	160M	ø125	ø100	283	323	353	294	470	720	520	318	1339	1050	400	125	440	395	50	100	120	28	19	146	109	49	304						
		345				294		318				1383	1050	400	125	136									49	331							
		351				317		343				1411	1100	400	150	161									51	358							
		370				312		343				1471	1100	400	150	182									51	379							
		425.5				364		318				1566	1150	450	125	295									53	494							
EHS 150C	B	160M	ø150	ø125	325	323	400	294	470	790	570	365	1381	1050	400	125	440	395	50	100	120	28	19	166	109	49	324						
		345				294		365				1425	1050	400	125	136									49	351							
		351				317		390				1453	1100	400	150	161									51	378							
		370				312		390				1513	1100	400	150	182									51	399							
		425.5				364		365				1608	1150	450	125	295									53	514							
		432				-		390				1623	1200	450	150	365									56	587							

• 치수는 참고용임